



User Instructions

Electric Conveyor Toaster CT1

Please make a note of your product details for future use:

Date Purchased: _____

Model Number: _____

Serial Number: _____

Dealer: _____

Dear Customer

Thank you for purchasing this **Lincat** product.

With correct use and careful maintenance as described in these instructions, your **Lincat** product will give years of trouble free use.

We produce over 450 different items of catering equipment and our range is constantly being extended and improved. Find out more about **Lincat** products from your local distributor or direct from us.

CONTENTS

CONTENTS.....	2
SAFETY INFORMATION	3
DELIVERY CHECKLIST.....	4
TECHNICAL SPECIFICATION.....	4
ACCESSORIES.....	4
INSTALLATION	4
OPERATING INSTRUCTIONS.....	5
CLEANING	7
MAINTENANCE	7
SPARE PARTS	9
SERVICE INFORMATION.....	10
GUARANTEE	10



SAFETY INFORMATION

To prevent injury to yourself or your staff, and to avoid damaging the product, please read and follow the safety precautions below before setting up and using the unit:

- Remove all plastic coatings and clean the unit before use.
- Ensure that the electrical supply cable is not damaged. If it is, it must be replaced by Lincat Ltd or by qualified personnel.
- Always disconnect the unit from the electricity supply before servicing.
- The unit must be earthed.
- Do not try to modify this unit.
- Never clean the unit with a water jet or steam cleaner.
- Inform staff that the surfaces and base will become hot.
- Keep these instructions in a safe place in the kitchen for future reference.

DELIVERY CHECKLIST

If an item is missing please contact your dealer immediately.

- Electric conveyor toaster (with electrical supply cable and 13 amp plug)
- 1 x wire feed rack
- 1 x crumb tray
- 1 x toast tray (with 2 bolts)
- User instructions
- Guarantee card

TECHNICAL SPECIFICATION

Model		CT1
Width	mm	410
Depth	mm	668 (max. inc toast tray)
Height	mm	398
Power Rating	kW	2.4
Net weight net	kg	21.0

ACCESSORIES

Control cover CT1/CC Cover to prevent tampering with controls

INSTALLATION

- Install the unit on a heat-resistant work surface
- Make sure that the surface is firm and level.
- Inform all users that the surfaces and base will become hot
- For safety regulations the plug or means of disconnection must always be accessible

Connecting to the electricity supply

- The unit must be earthed
- Check that the voltage of your electricity supply corresponds to the voltage shown on the serial plate
- The product is supplied with a 13 amp plug. If replacing the plug, connect the terminals as follows:
 - Green and yellow wire Earth E
 - Blue wire Neutral N
 - Brown wire Live L

Fig 1 : Parts identification

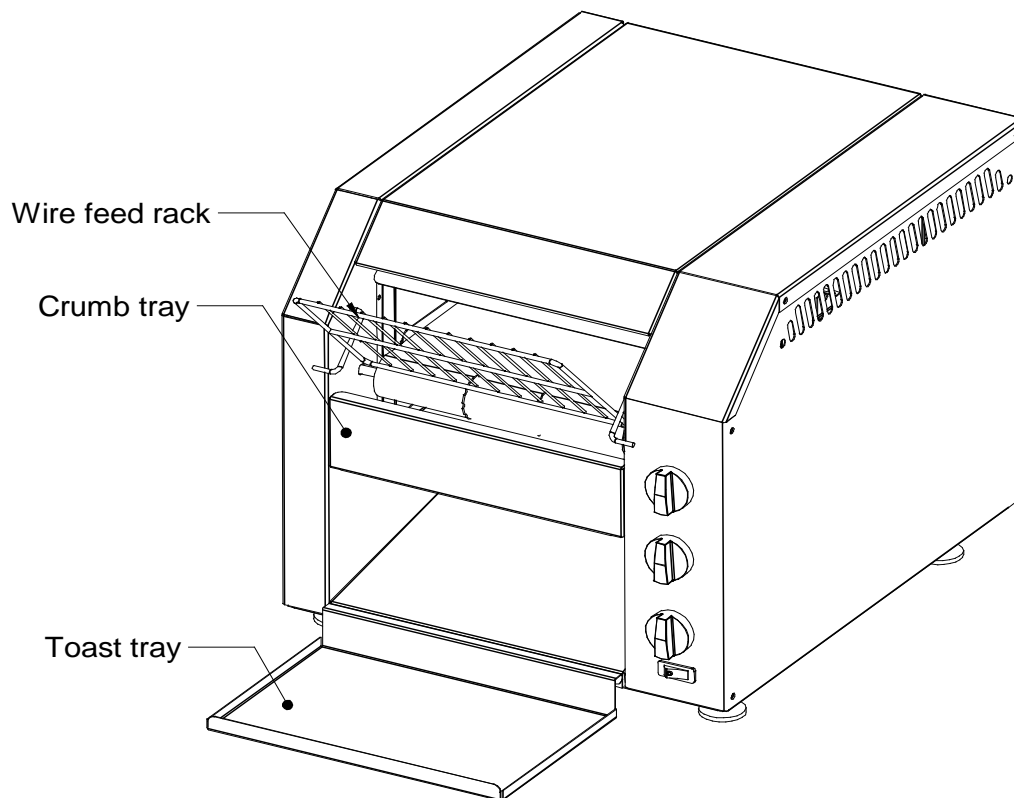

OPERATION

Figure 2: CT1 Controls

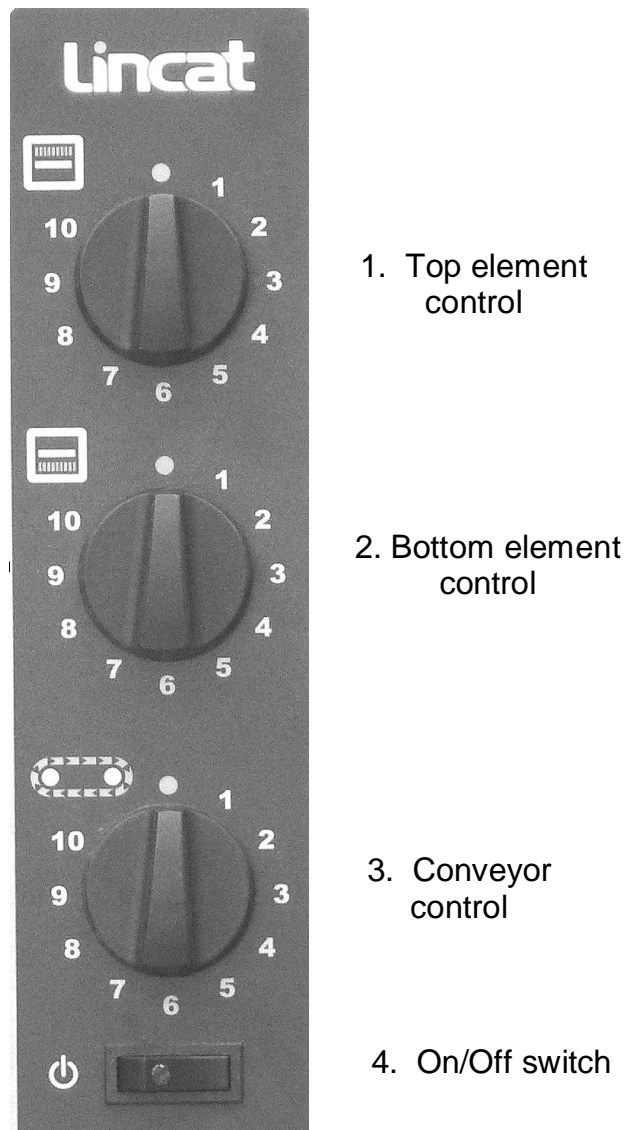

Preparation

- 1 Connect the unit to the electricity supply.
- 2 Turn the switch (4) on: the switch illuminates.
- 3 Turn the element control knobs (1 and 2) to the required temperature.
- 4 Turn the conveyor control knob (3) to the required speed.
- 5 Wait 10-15 minutes for the toaster to heat up.

Toasting Tips

- You will need to adjust the temperature and conveyor speed to achieve the best results for each type of bread you use.
- Single slices will require a different setting from two slices side by side..
- Best results are obtained by using bread which is at least one day old.
- The elements may be turned to a lower temperature to save energy during quieter periods.
- To toast single sided bread products (buns etc), set the bottom element at a higher temperature than the top element. For stability, the flat (cut) side of the product should face downwards. This will then warm but not toast the uncut side of the bread.
- It is important to note that any item placed on the belt will return upside down into the toast tray.

CLEANING

- Clean the unit regularly to maintain performance and hygiene.
- Disconnect the unit from the electricity supply and allow to cool before starting to clean
- To cool the unit quickly, switch off both elements and turn conveyor to low, leave fan running until unit has cooled.
- Wipe the unit down with a damp soft cloth.
- Do not allow excess water to run into the unit.
- Do not use abrasive creams or scourers.

MAINTENANCE

The parts listed below can be replaced by the user. No other regular maintenance is required.

- **Toast Tray**
 - Lift the tray up and remove. Clean, and reverse procedure to replace.
- **Crumb Tray**
 - Switch off unit and allow cool. Pull forward.
Warning – Do not attempt to remove crumb tray when unit is operating as it will be hot.

- **Feed Rack**

To remove feed rack see drawing below:

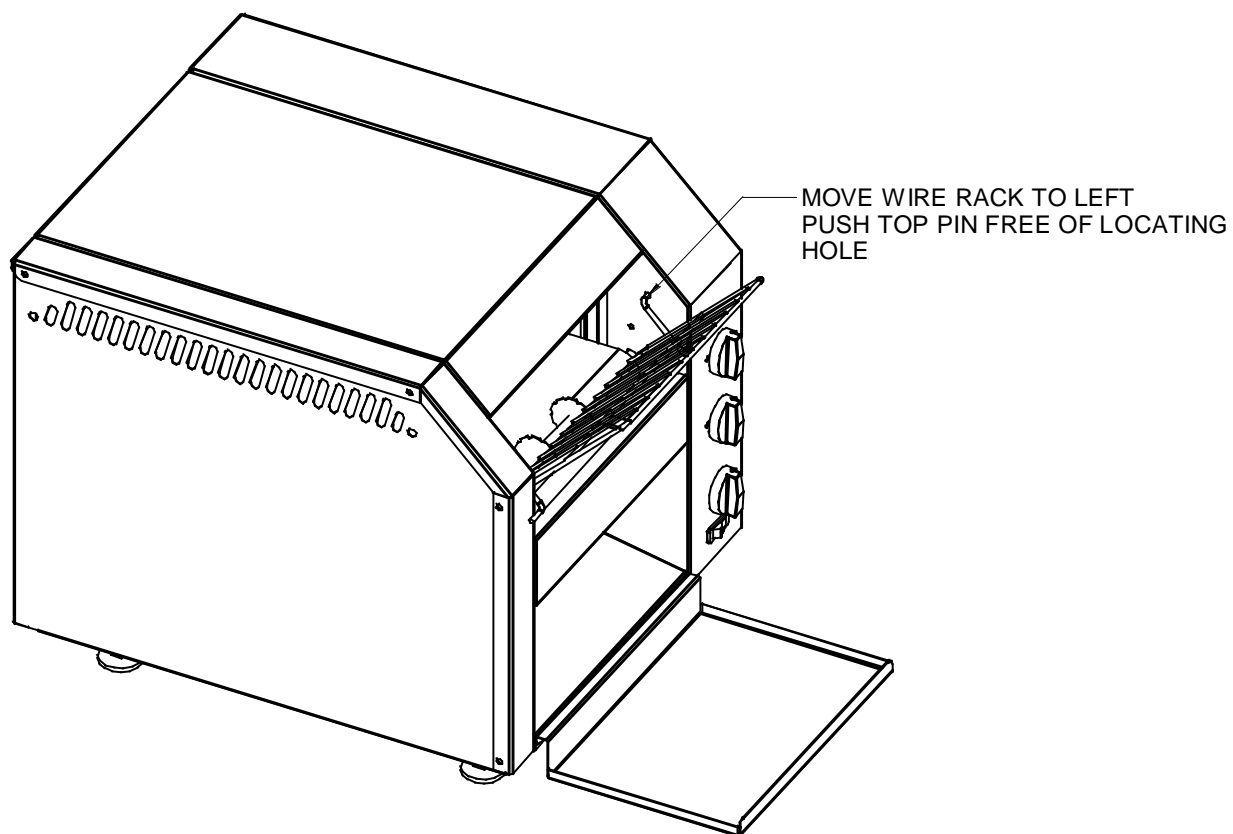

For replacement of parts in the Spare Parts List please contact your dealer.

SPARE PARTS

Description	Part No	No Per
PTFE bearing	BE11	4
Conveyor chain	CV02	1
Drive chain	DC08	1
Diode	DI28	1
Top element 1.3kW	EL239	1
Bottom element 1.1kW	EL240	1
Energy regulator	EN10	2
Fascia panel	FA30	1
Adjustable foot	FE10	4
Fan guard	FG03	1
Control knob	KN251	3
Motor with fan blade	MO13	1
Electric cable	PL202	1
Rheostat	RH01	1
Cooling fan	S/R0079	1
Sprocket for drive chain	SP09	2
Spindle extension for conveyor control	SP75	1
On/Off switch	SW53	1
Feed rack	WR05	1
Toast tray	TR52	1
Crumb tray	TR53	1

SERVICE INFORMATION

For help with the installation, maintenance and use of your **Lincat** equipment, please contact our service department:

☎ UK: 01522 875520

All service work, other than routine cleaning should be carried out by one of our authorised service agents. We cannot accept responsibility for work carried out by other persons.

To ensure your service enquiry is handled as efficiently as possible, please tell us:

- Brief details of the problem
 - Product code
 - Type number
 - Serial number
- } From serial plate

Lincat reserve the right to carry out any work under warranty during normal working hours, ie Monday to Friday, 08:30 a.m. – 17:00 p.m.

GUARANTEE

This unit carries a comprehensive UK twelve-month warranty. The guarantee is in addition to, and does not diminish your statutory or legal rights.

The guarantee does not cover:

- Accidental damage, misuse or use not in accordance with the instructions in these instructions
- Consumable items
- Damage due to incorrect installation, modification or unauthorised service work
- The manufacturer disclaims any liability for incidental, or consequential damages

This page intentionally left blank

This page intentionally left blank

This page intentionally left blank